

Enviro Division



PULSE JET BAG FILTER

Custom Engineered Fabric Filter Systems

Cleaning the air for better returns

Thermax and Fabric Filter Systems

Improving your business is our business

Thermax offers products, systems and solutions in energy and environment engineering to industrial and commercial establishments around the world. Its business expertise covers heating, cooling, waste heat recovery, captive power, water treatment & recycling, air pollution control & waste management and performance chemicals.

Thermax brings to customers extensive experience in industrial applications expertise through technology partnerships and strategic alliances.

Operating from its headquarters in Pune (Western India), Thermax has built an international sales & service network spread over South East Asia, Middle East, Africa, Russia, UK and US. It has full fledged ISO 9001:2000 and ISO 14000 accredited manufacturing setup.

Enviro Division

Enviro Division was conceived with a belief that *pollutants are inevitable but pollution is not*. An acknowledged leader in Air Pollution Control & Purification business, it offers a wide range of flange to flange products, customised systems & value added services. Thermax Enviro is present in most industry segments, viz. cement, steel, non-ferrous metallurgical, power plants, fertilisers, tyres, paper, chemicals, petrochemicals textiles etc.

Ever since its inception in 1980, Thermax-Enviro has been engaged in the design and manufacture of *Fabric Filter Systems* with different configurations to suit different applications. The product range on offer today covers Pulse Jet Bag Filters and Reverse Air Bag Houses both structurally supported free-standing on-line and modular off-line type units as also insertable type units.

A basic precept of Thermax has been the pursuit of quality in every product or system that bears the Thermax stamp. This pursuit of quality is especially important in fabric filter systems - where attention to application engineering, design detail and quality of fabrication can mean the difference between outstanding performance and mediocre, high maintenance service. Be it process applications like boilers, furnaces, kilns and mills, or material handling nuisance venting catering to more than 50 different types of dust Enviro has been there before.

Thermax has, over the years, absorbed fabric filtration technology from two leading organizations of their time – Zurn Industries Inc. USA & General Electric Environmental Services Inc. USA – and progressively build on the same with in-house application engineering strongly supported by field trials.

The Thermax Pulse Jet Bag Filter

■ **On Line:** In an online bagfilter, bags are cleaned row by row, even while the dust laden gas is filtered concurrently. The sequence of cleaning is controlled automatically by a sequence controller. This operates the assembly of solenoid and pulse valves which direct the air flow into the manifolds. The holes are jig drilled for perfect alignment with the venturi centre for achieving maximum cleaning efficiency.

■ **Off Line:** It incorporates the advantages of a pulse jet bag filter as well as that of a reverse air baghouse. Each compartment is similar to an online pulse jet bag filter. The cleaning process consists of sequentially isolating each compartment and then cleaning the isolated compartment with compressed air. Offline cleaning is suitable for light and fine dust where occurrence of fluidization is a distinct possibility. Generally the Offline Bag Filter is employed for larger gas volumes

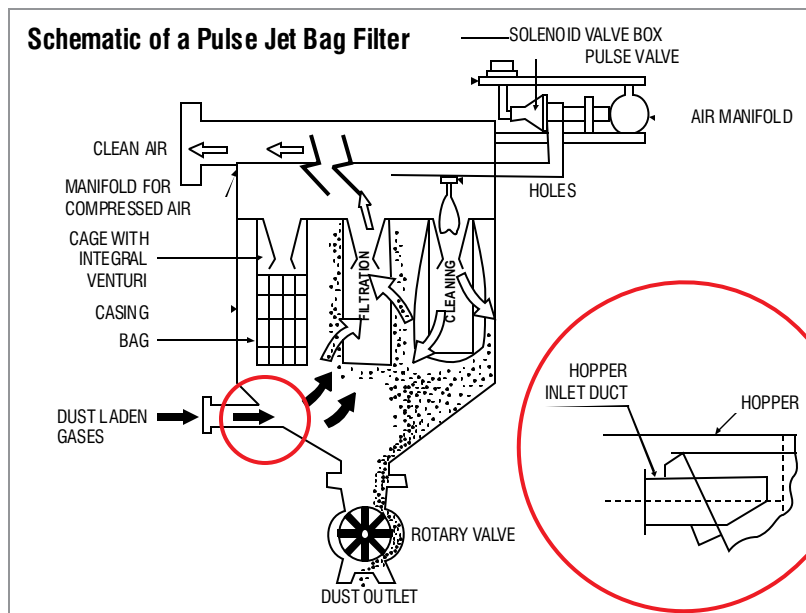

The Thermax Pulse Jet Bag Filters - Online

1) Regular Hopper Entry

The pulse jet bag filter in its most rudimentary form basically consists of the filtration elements housed in a casing. Below this casing is a hopper with a discharge valve, to continuously remove the dust that is collected on the bags. The entire unit is supported from the ground on structural legs. A caged ladder provides access to the top of the unit for maintenance.

The dust laden air enters through the hopper by suction (normally) or (positive pressure). The heavier dust particles fall off at the entry itself, while the lighter dusts get carried upward to the bags.

The dust gets deposited on the outer surface of the bags and the clean air moves upward from the center of the bags through the outlet plenum to the top air outlet. **This is known as filtration.** The dust collected on the outer surface of the bags is removed in a pre-determined cycle by a momentary pulse of high-pressure compressed air. The compressed air moves from an air reservoir or compressed air header via the particular pulse valve into the compartment manifold and thereon into the bags in the row beneath it. The pressurised entry of compressed air through the venturis into the bags, inflates the latter, and the dust cake formed on the bag surface slides down in the form of flakes. The cages help the bags retain their original shape once the effect of the compressed air is gone. This completes the **cleaning process.** The dust slides down the hopper walls to the rotary air lock valve. The latter is a rotating device which discharges the dust continuously, all the while maintaining an air seal.

Thermax's range in above construction covers both completely standardized and pre-engineered Bag Filters - the AJ/ AP series – up to a particular size with customized variations also available beyond this.

2) Flush Mounted - Insertable

Transfer points involving two conveyors or from one conveyor to / from other material handling equipment often involve isolated point(s) where free standing bag filter(s) can be an expensive proposition. Space availability on ground is also an issue at times. Typically, these *insertable bag filters* units are devoid of any hopper. The unit can be suitably positioned on the conveyor directly. On pulsing, dust falls back onto this conveyor, thus avoiding a need for a separate dust discharge hopper.

Depending on the height of fall of dust, two such insertable bag filters may be required – one at the end of the discharging conveyor and one on the receiving conveyor. When a single unit is used, it is normally on the receiving conveyor – as shown in the adjoining figure – this being where generation of dust is higher due to impact. These type of units are also optimal solutions for venting of bins / silos / hoppers.

The units in this construction are mostly standardized and pre-engineered, though customized variations can be offered where necessary.

Opened up image

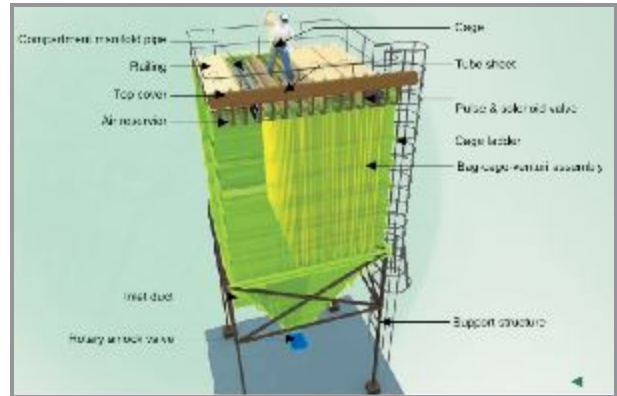

Opened up Image

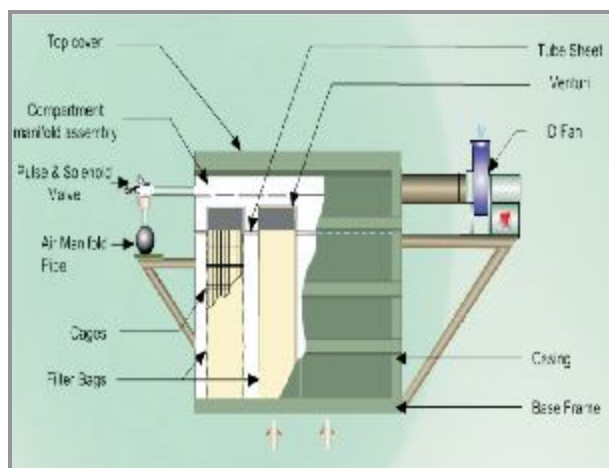

Air Flow

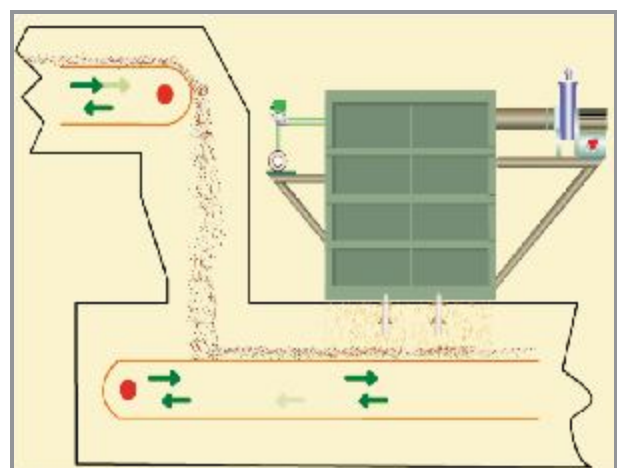

3) Flush Mounted - Circular

The construction here is similar to an insertable bag filter; however, in this case, the casing of the bag filter is circular instead of being rectangular. The top cover could be a dished end – as in the adjoining figure – which is used for high positive design pressure or vacuum, as is typically a situation encountered for applications related to venting of silos / bins connected to pneumatic conveying systems

Opened up image

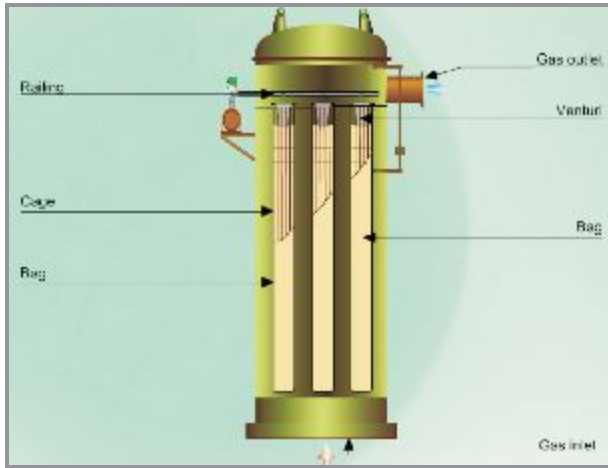

Air Flow

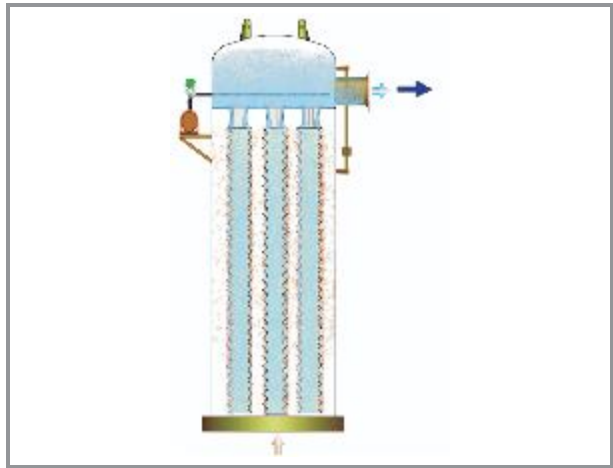

4) Casing Entry

Here the dirty gas enters the casing – through the inlet-cum-bypass damper in boiler bag filters (as in the sketch alongside) – and flows into a central chamber formed by perforated sheets. The gas flow towards the bags is partially through the perforations and partially upward from below of the sheets, ensuring better gas distribution and the separation of heavier dust respectively.

The lighter dust gets carried upward to the bags. This gets deposited on the outer surface of the bags and is removed by a pre-determined cycle by a momentary pulse of high pressure compressed air as in the case of a typical hopper entry type of bag filter.

Thermax's range in above construction is also completely standardized and pre-engineered - the AJC / APC series - upto a particular size.

Opened up image

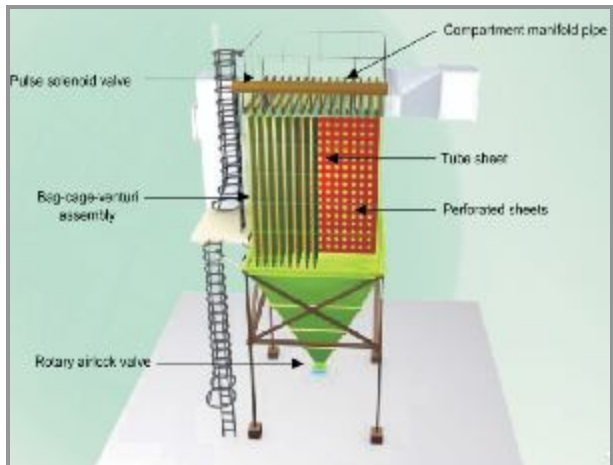

Opened Up Image

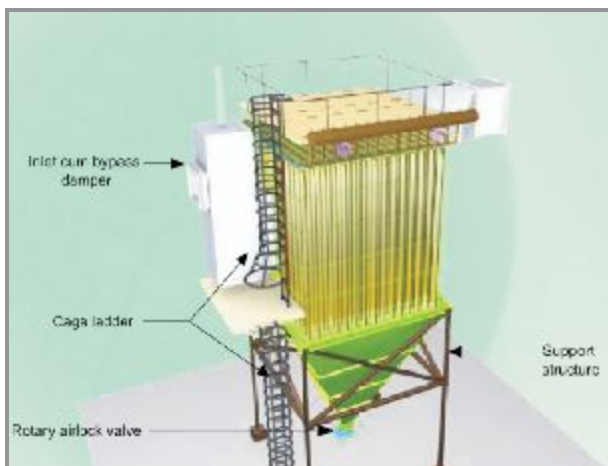

Air Flow

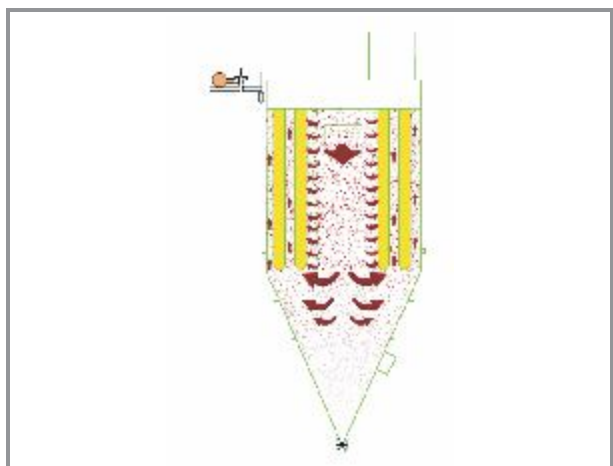

5) Circular - Tangential Entry

The gas enters into the bag filter tangentially at the bottom of the casing. This gives the dust laden gas a circular motion which helps in removing the heavy & coarser particles that are present in the gas stream in a manner similar to a cyclonic collector. These collected particles are directly discharged into the hopper. It is only the very fine particles that get carried to and collected on the bag surface. Thus the total dust load on bags is reduced making it possible to maintain lower pressure drop across bags. This also permits the use of lesser frequency of bag pulsing, which in turn increases bag life.

Opened up image

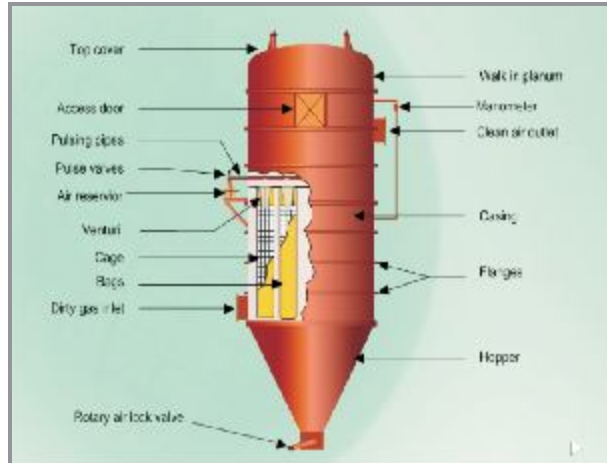

Air Flow

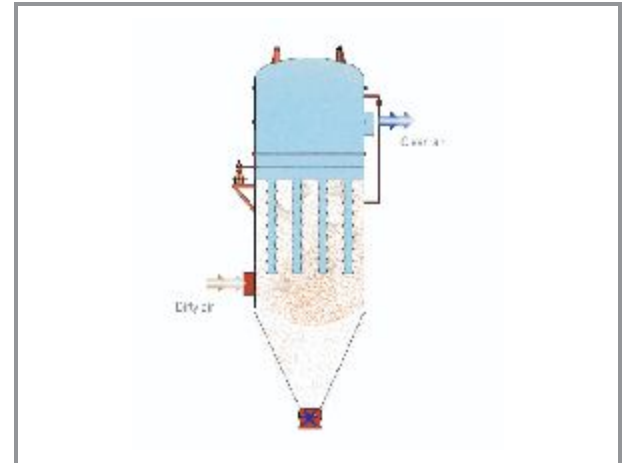

Due to its circular construction, these bag filters can withstand more +/- pressure as compared to normal rectangular bag filters. The circular construction of bag filter also ensures leak proof ness. The possibility of dust accumulation inside casing (on edges etc.) is eliminated. Due to the arrangement of bag as shown in the image alongside, each and every bag is exposed to the dust laden gas. The swiveling arrangement shown enables the top cover to be pushed to on one side and lifting of the same. Due to special top cover and outlet plenum construction the entry of outside air is avoided.

6) Pre-separator Extended Hopper

In the Pre-separator extended hopper type of unit, the dirty gas enters in the common inlet plenum formed as an aisle between the two filter modules resulting in pre-separation of the dust laden gases.

From there it flows to both the modules undergoing filtration as in a regular unit.

The cleaned gases travel back to the common outlet plenum from the individual clean air plenums and then flow out through the outlet duct to the ID fan.

Bag Cage Removal / Replacement

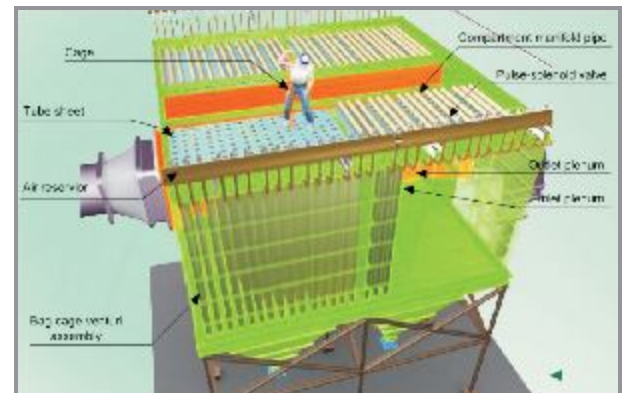

7) Pre-separator Casing with Baffle - TKB Series

The phenomenal growth of the Cement Industry has seen the advent of plants of much bigger size. The conventional bagfilters have been found to be inadequate to handle large gas flows in excess of 6,00,000 m³/hr. This is due to severe limitations on aspects like high gas flow per bag, high velocity of gases through bag filter, higher pressure drop across filters, high space requirement and high compressed air consumptions.

To overcome these limitations, Thermax has designed a new series of bag filters – the TKB series.

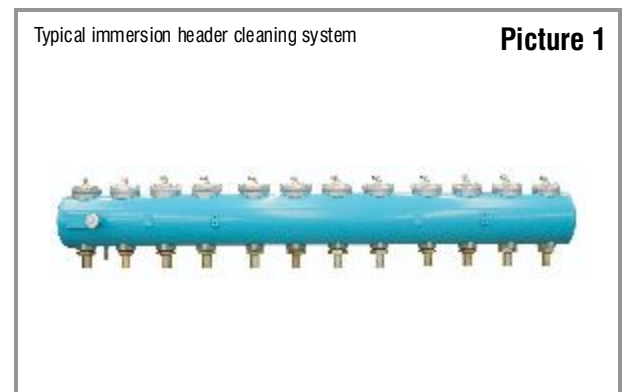

Some of the unique features incorporated in the TKB series are highlighted below.

A. Low pressure air cleaning system:

The TKB Pulse Jet Bag Filter (PJBF) long bag design incorporates a specialized low pressure cleaning system that offers following distinct advantages over conventional bag filters with high pressure cleaning system:

1. Lower pressure drop across the unit.
2. Lower consumption of compressed air.
3. Longer filter bag life.
4. Lower noise levels during operation.

The low pressure cleaning system uses a special immersion type header mounted pulse valve as shown in Picture 1. This cleaning system is so effective that it achieves 25% more cleaning pressure on the bag. The impulse is built in half the time it takes conventional system (Picture 2).

- Effectively flushes the bag & reduces re-deposition of fine dust.
- Can clean bags up to 10 meters length.
- Cleans the internal of the filter media to have lower longer term pressure drops.
- The filter media is not flexed as extensively as in the conventional cleaning, thereby increasing media life.

B. Unique gas flow path:

The TKB series filters are specially designed for high inlet dust loads. The gases enter the filter casing entry plenum behind a baffle and are directed upwards by this specially designed baffle. The 90 degree turn that the gases take on entry helps in separating a lot of dust. This reduces the dust load on bags. The unique gas flow path makes the gases enter the filter with an upward bias on the velocity. This upward bias reduces impact of the dust particles on bag surface enhancing the life of the bags. The gas flow path is shown in Picture 4.

C. Wider pitch of bags:

The bag pitch – the centre to centre distance between the bags – plays a very important role in the performance of the bagfilter. In order to address the high gas flows and very high dust loads involved the TKB series filters has adopted an increased spacing between bags – as much as 36%. This additional clear space allows the high amount of dust load to fall by reducing gas velocity between bags. This also reduces the sliding friction at bags enhancing the life of the bags.

D. Specially reinforced cages:

The conventional cages can not be used in bag filters as there is a tendency to bend due to the excessive length. Higher thickness wires are used for cages when the height of bag or cage is 6 m or more than that. This higher thickness ensures straightness of the cage as this actually ensures the spacing between bags which are freely suspended from the bag filter tube-sheet.

The above features of the Thermax TKB bag filters has made this the most popular design in the Indian Cement industry.

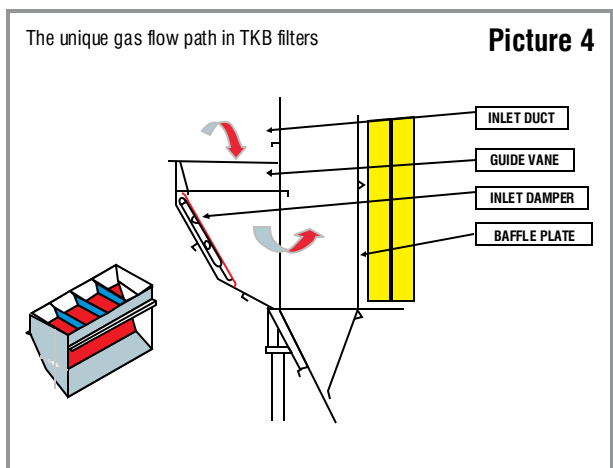
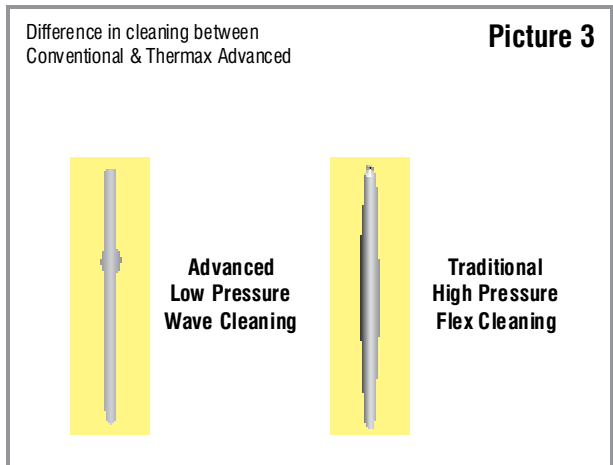
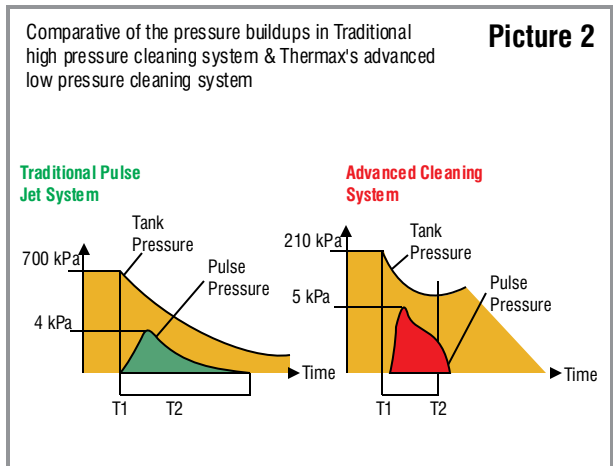

The Thermax Pulse Jet Bag Filters - Off Line

An Offline Bag Filter is used when the dust in gases is very light and fine. In an online bag filter, the dust that is dislodged from a row of bags may be picked up by the adjacent row of bags as the latter is under suction. The dust may remain in suspended condition – especially if it is light and / or fine – the reverse upward gas flow not allowing the dust to settle in the hopper. This phenomenon is called *fluidization of dust*.

This fluidization of dust results in high differential pressure across the bag filter, abrasion and ultimately choking of bags. This is where an offline bag filter is employed.

Opened up Image

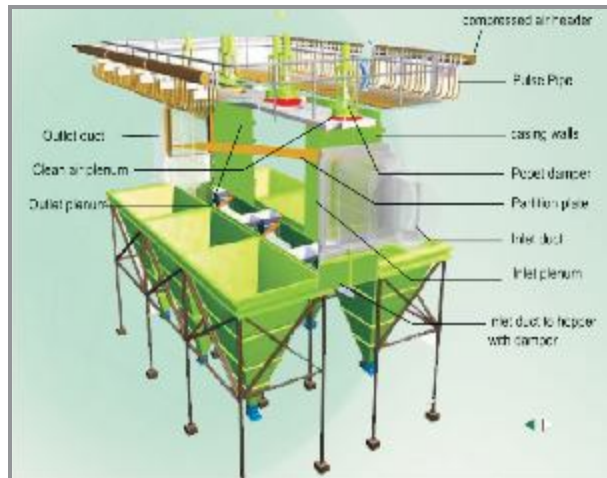

Opened up Image

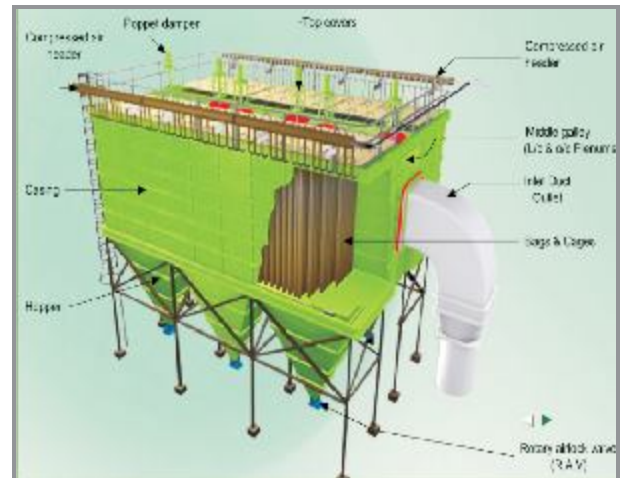

Opened up Image

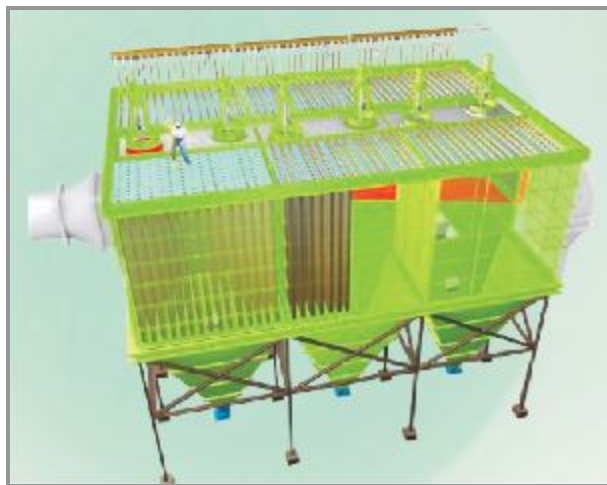

Air Flow

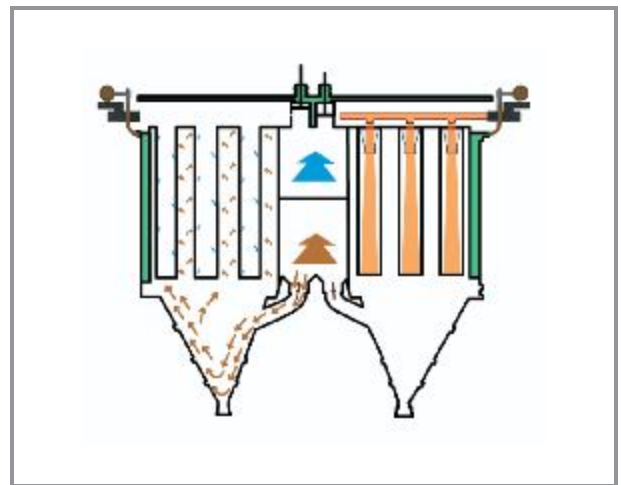

Working :

The Offline Bag Filter typically contains 4 to 6 bag filter compartments or modules. Each compartment is similar to an online bag filter. However, here the gas flow through a compartment is stopped temporarily when the pulse cleaning of the bags is to be done in that compartment.

The dust dislodged from the bags settle easily in the hoppers because of the absence of any counter-current gas movement in this compartment. The dust so collected is discharged from the hopper through the rotary airlock valve.

During this time the remaining compartments keep filtering the gases as usual. Each compartment is cleaned one after another in this manner.

The starting & stopping of gas flow through individual compartments is achieved through a compact pneumatically operated poppet damper system located at the outlet of each module. While the pulsing in individual compartments are controlled by means of a *compartment sequential controller*, the sequence of operations of the different compartments with respect to each other are controlled by a *master sequential controller*.

Components Types & Benefits

Fabrics

Table of Typical Characteristics

Fabric type	Can withstand maximum temp.	Resistance to				
		Flex abrasion	Moisture	Acid	Base	Organic
Polypropylene	90°C	Good	Excel.	Excel.	Excel.	Excel.
Acrylic	120°C	Good	Good	Good	Good	Good
Polyester	130°C	Excel.	Fair	Fair	Poor	Good
Nomex®	190°C	Good	Poor	Poor	Fair	Good
Fibreglass	260°C	Poor	Excel.	Excel.*	Excel.	Excel.
PPS	180°C	Good	Good	Good	Excel.	Good

® Registered trade mark of Du Pont Co.

* Except Fluorine

Filtration Principle in woven fabric

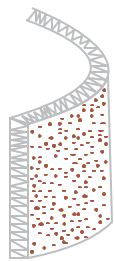

In a woven fabric, the particle gets collected by one or more of the mechanisms (like interception, internal impaction etc.) resulting in a build up of 'dust cake' which is mostly on the surface.

Filtration Principle in non-woven fabric

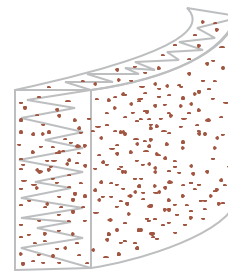

In a non-woven fabric, the filtration is not only on the surface resulting in a build up of 'dust cake' but also in-depth.

Bag / Cage / Venturi Arrangement

Cages are wire frames placed inside pulse jet filter elements to provide support to the fabric as flexing occurs during filtration and cleaning cycles. Configuration of a frame generally follows the shape of the filter elements, i.e., circular, oval, flat or star-shaped. Cages for long filter elements are made in sections which snap together for easier handling. Wearpoints on filter bags may develop at the horizontal supports.

Cage designs to reduce these points increase the number of vertical wires and reduce the horizontal supports. Protective coatings on cages can extend the life of the cage and the bag. Coatings such as vinyl, epoxy, zinc, and Teflon® may be used.



Snap Type Ring Bag

Typical Bag Fixing & Pulse Pipe Arrangement (Snap Ring)

Notes :

1) Procedure for bag removal :

Remove top covers & pulsing pipes

2) For Inspection & removal of bags :

It is required to disassemble respective pulsing pipe above the bag row.

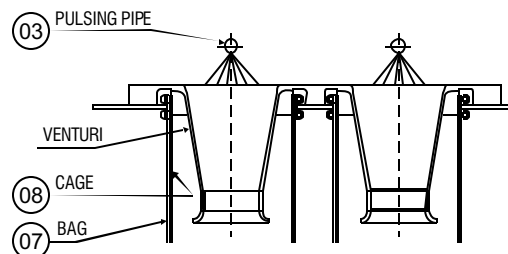

Solenoid Pulse Valve

The pulse of compressed air is controlled by series of pulse solenoid valves that are placed on air reservoir. These in turn are connected to compartment manifold pipe, which open above the venturi of each bag in that row.

The diaphragm of the pulse valve is closed as the compressed air is trapped between diaphragm and solenoid valve orifice. When the solenoid valve is energized through an input signal from the sequential controller, the trapped air flows from the top of the diaphragm through the orifice of the solenoid valve.

The inflowing compressed air lifts up the diaphragm and flows through the outlet of the pulse valve. Again when the solenoid valve is de-energized, the air gets trapped, closing the diaphragm as a result of pressure equalization.

The next solenoid valve gets energized and the entire process is repeated sequentially in cycle

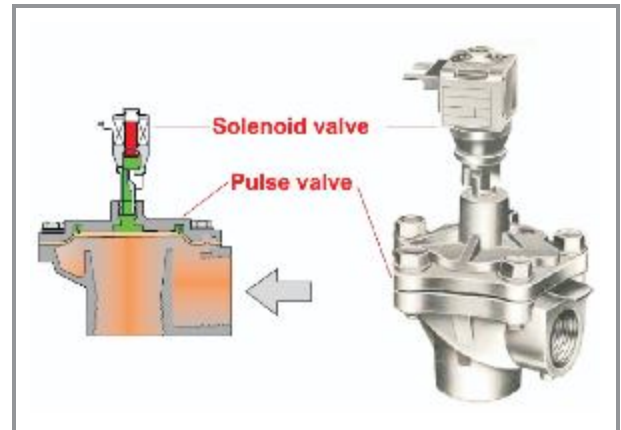
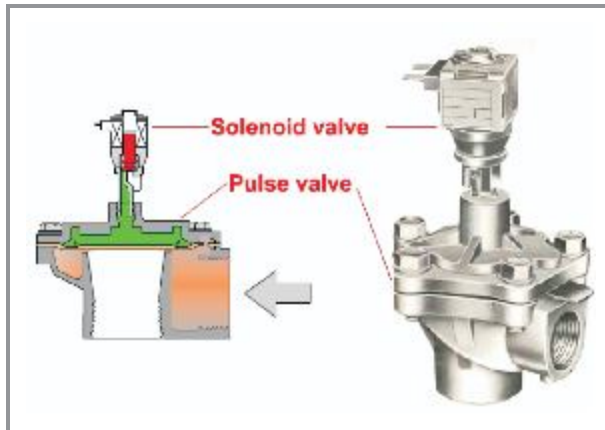

RAV (Rotary Airlock Valve)

The rotary air lock valve maintains an air seal preventing its passage into the hopper from below.

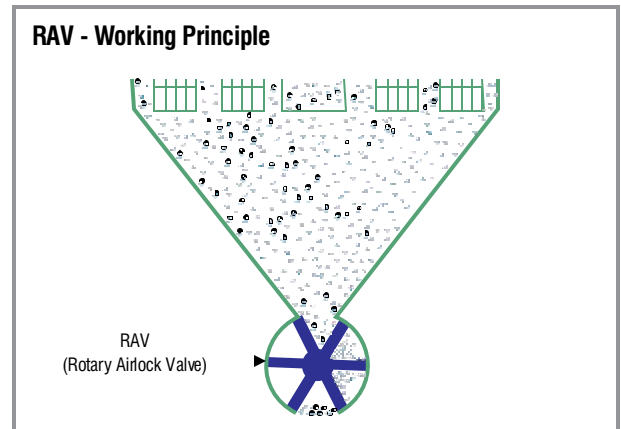

Poppet Damper

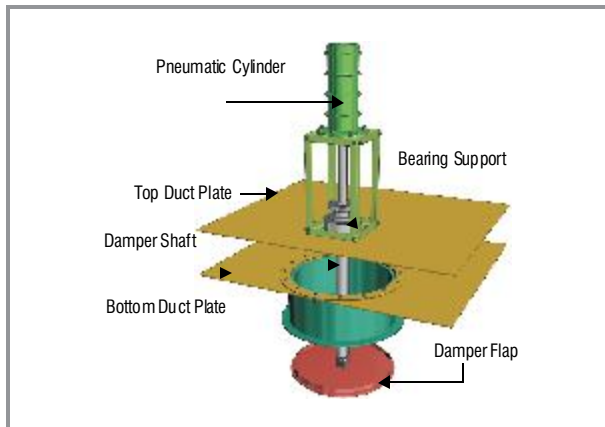

Application Matrix

Industry	Application
Steel	Furnace - Process / Material Handling
	Cast House / Stock House
	Boiler
	Kiln / Reactor Exhaust
	Coal Preparation / Injection
Cement	Coke Oven
	Clinker Cooler
	Coal Mill
	Cement Mill
	Kiln / Reactor Exhaust
	Transfer Point - Dedusting
Power	Alkali Bypass
	Material Handling
Agro Based /Sugar / Rice /Tobacco	Boiler
	Material Handling
Breweries & Distilleries	Boilers
	Material Handling
Dairy	Boilers
	Dryers
Drugs & Pharmaceuticals	Boilers
	Dryers
	Material Handling
Food Processing	Boilers
	Dryers
Paper & Pulp	Boilers - Process / Recovery
	Mill
Solvent Extraction / Edible Oil	Boilers
	Material Handling
Sponge Iron	Kiln / Reactor Exhaust
	Material Handling
Textiles	Boilers
	Material Handling
Soaps ,Detergents & Waxes	Boilers
	Material Handling
Non Ferrous Metallurgical	Smelter / Furnace
	Ovens
	Material Handling
Paints & Dyes	Boilers
	Material Handling
Tyres	Boilers
	Banbury Mixers
Wood	Boilers
	Dryers
	Material Handling

Systems Build around

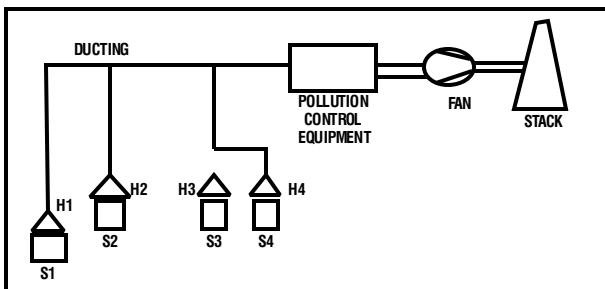

- Exhaust hoods (H1 to H4) to capture fugitive dust at the emission sources (S1 to S4).
- Ductwork to transport captured dust to a dust collector.
- A dust collector to remove the dust from the air.
- A fan and motor to provide the necessary exhaust volume and energy.

Coal Injection System for blast furnace

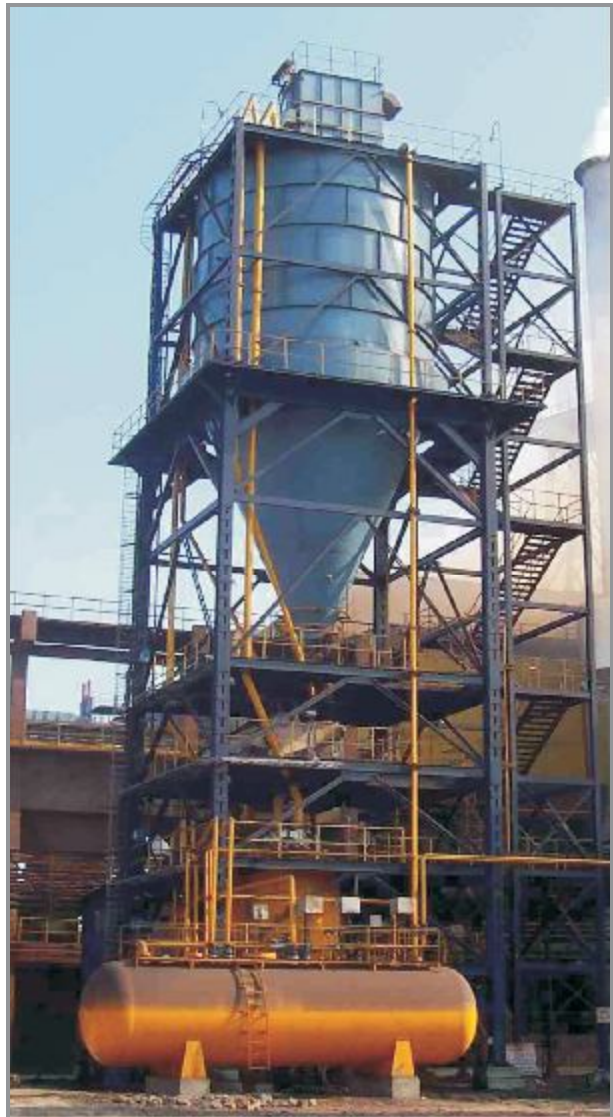

Customer Appreciations

■ Carbon Black/Tyres:

Hi-Tech Carbon, Philips Carbon Black, CACIL, Birla Tyres, Apollo Tyres, Bridgestone India, Goodyear Tyres

■ Cement & Rock Products:

Gujarat Ambuja, L&T, Madras Cement, ACC, Grasim Industries, Jaypee Cement, Dalmia Cement, Vasavadutta Cement, OCL, Penna Cement

■ Chemicals / Detergents:

HLL, GHCL, Nirma, National Peroxide, Solvay Vishnu, Kanoria Chemicals, Shriram Alkalies, Johnson Matthey

■ Fertilisers:

CFL, GSFC, IFFCO, OCFL, HLCL, Paradeep Phosphates, SPIC, MCFL

■ Food & Edible Oil:

Nestle, Lipton, Nutrine, Van Melle, Ruchi Soya, Mohan Breweries, Rasoi Group, Agarwal Industries

■ Glass :

Saint Gobain, Schott Glass, Videocon
Narmada, L&T Glass, Philips, Aglglaspac, Gujarat Glass

■ Iron & Steel :

TISCO, Sesa Goa, Ispat Group, Aarti Steels, Jayaswal Neco, Bhushan Steel, Jindal Group, Vardhman Group, Steel Authority India Ltd. - BSP, BSL, RSP, VSP

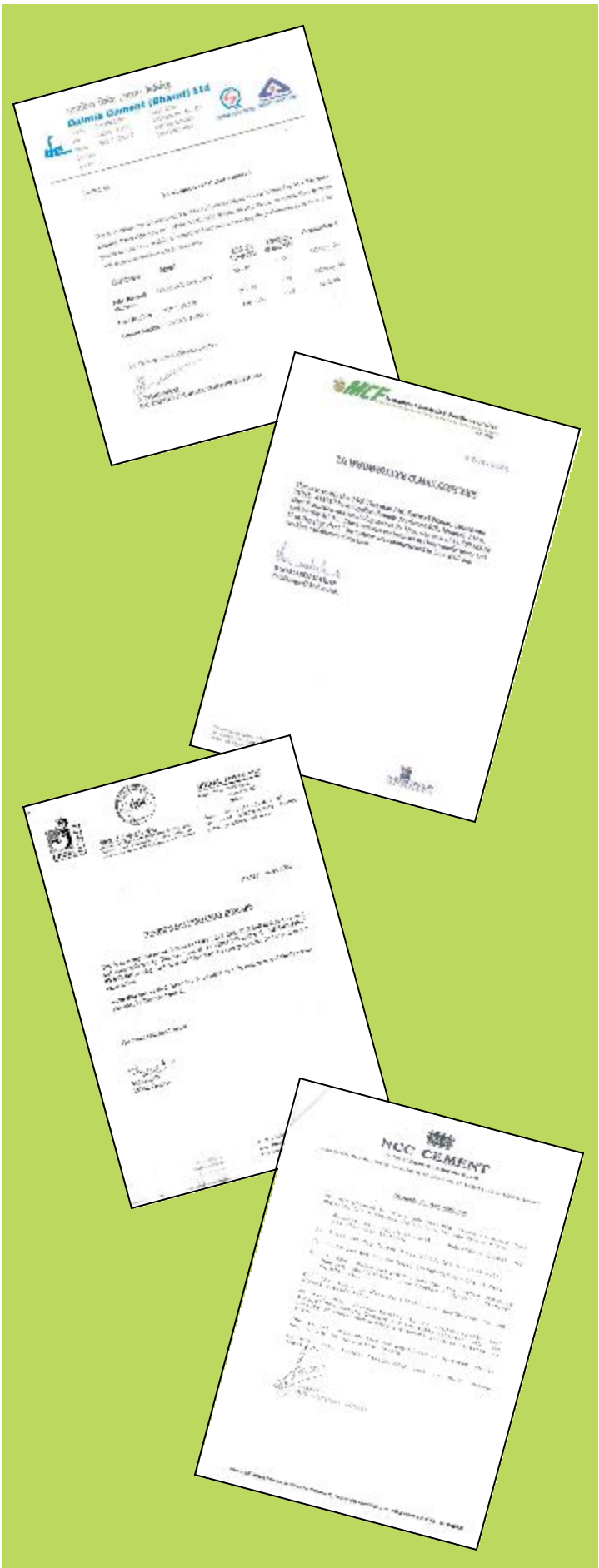

Thermax Enviro Portfolio

Air Pollution Control

- Baghouses - Reverse Air, Pulse Jet & Insertables
- Electrostatic Precipitators - Dry & Wet
- Particulate Scrubbers - Venturi, Cyclonic, Impingement Plate
- Gaseous Scrubbers - Packed Bed, Spray/Tray Towers
- Flue Gas Desulphurization (FGD) Systems
- Fume Extraction and Dedusting Systems including Cast House and Stock House Application
- Coal Preparation Plants & related systems
- Coke Ovens: Pushing Emission Control Systems & Coke Dry Quenching
- Renovation & Modernization for Capacity Enhancement & Lower Emission Norms

The division also undertakes turnkey projects to offer complete technology on air pollution control and its management.

The Pulsejet Bag Filters on Front Cover



Specialised Dedusting system in a cast house



Modular pulse jet bag filter on a lime / dolomite kiln



A typical casing entry bag filter with spark arrestor for Metalurgical Application



Cement Mill Bag Filter in a Cement Plant

In order to take advantage of future technical developments we reserve the right to modify the details given in this document



THERMAX

Sustainable Solutions in
Energy & Environment

Registered Office

D-13, MIDC Industrial Area,
R D Aga Road, Chinchwad,
Pune 411019, India

Tel : +91 20 66122999 / 66155000

Fax : +91 20 27472049

enquiry@thermaxglobal.com

Thermax Business Portfolio

- Heating
- Cooling
- Power Generation
- Air Pollution Control
- Chemicals
- Water and Wastewater Solutions
- Solar
- Specialised Services

www.thermaxglobal.com